

"V" SHAPED STAND TOP (BALL ROLLER) - STAND-T

APPROX WEIGHT: 11.18 lbs.
DOES NOT INCLUDE WEIGHT OF POWER OR PACKAGING!!!

*** ANY ADDITIONS, DELETIONS, OR OMISSIONS MUST BE CORRECTED ON THIS DRAWING AS THIS DRAWING WILL BE CONSIDERED ALL INCLUSIVE ***
ALL GRAPHICS PROVIDED ARE FOR REFERENCE ONLY. IF CERTAIN DIMENSIONS ARE CRITICAL PLEASE VERIFY THOSE DIMENSIONS WITH YOUR SALESPERSON

SHOWN WITH BALL ROLLER PLATES
ADJUSTED IN TOWARD MIDDLE

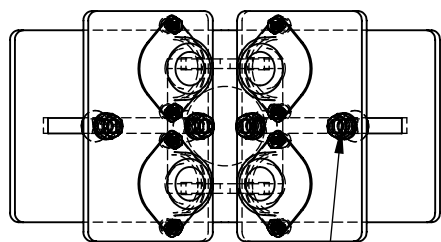

SHOWN WITH BALL ROLLER PLATES
ROTATED 180° AND ADJUSTED OUTWARD

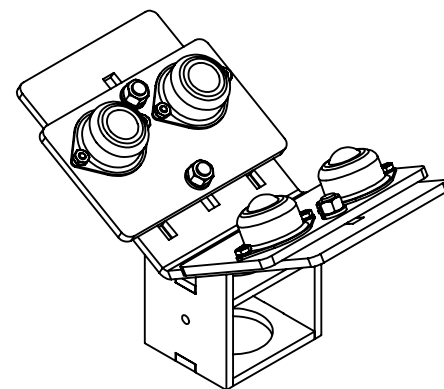
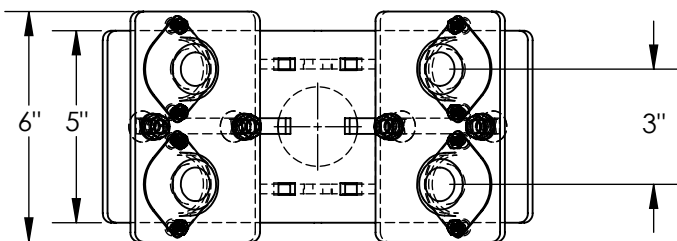

NUTS MAY BE LOOSENE
TO ALLOW $\phi 3/8$ " CARRIAGE
BOLTS TO SLIDE IN SLOTS FOR
ROLLER PLATE ADJUSTMENT

3 15/16" EXPANDED
1 9/16" RETRACTED

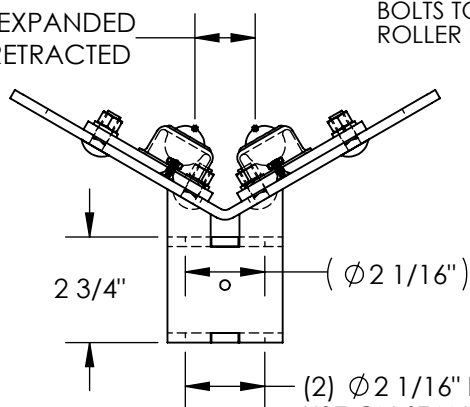

(2) $\phi 2 1/16$ " HOLES IN WELDMENT ALLOW
USE ON STANDS WITH $\phi 2$ " POSTS INCLUDING:
STAND-H, STAND-V, STAND-H-HP, STAND-V-HP,
STAND-G-H, STAND-G-V, STAND-G-H-HP,
STAND-G-V-HP

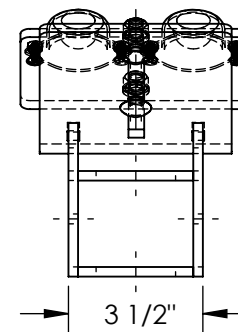
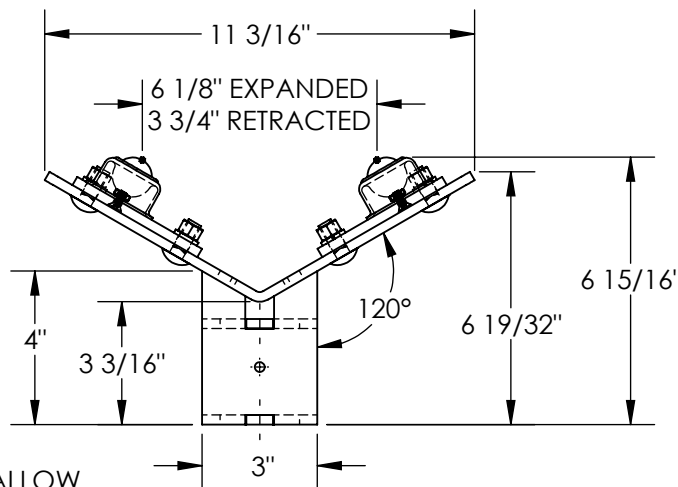

DIMENSION TOLERANCE $\pm 1/4$ "

STANDARD FEATURES

- MODEL NUMBER IS STAND-T
- OVERALL WIDTH IS 11 3/16"
- OVERALL LENGTH IS 6"
- OVERALL HEIGHT IS 6 15/16"
- ADJUSTABLE POSITION BALL ROLLER PLATE
- MAX BALL ROLLER WIDTH IS 6 1/8"
- MIN BALL ROLLER WIDTH IS 1 9/16"
- MAX CAPACITY IS 300 LBS.
- INCLUDES 4 SINGLE BALL TRANSFER ROLLERS
- TOUGH BAKED IN POWDER COATED BLUE FINISH

SPECIAL FEATURES

NONE

APPROVAL	I, THE UNDERSIGNED, AGREE THAT THE PRODUCT AS REPRESENTED SATISFIES DESIGN AND DIMENSION REQUIREMENTS. I ALSO ACKNOWLEDGE MY DUTY TO CONFIRM PRODUCT AND INSTALLATION COMPLIANCE WITH ALL APPLICABLE FEDERAL, STATE AND LOCAL REGULATIONS AND STANDARDS.	
	ANY MODIFIED UNITS ARE NON-RETURNABLE	
	[] As drawn [] As marked	
	Signed: _____	Date: _____
Printed Name: _____		
LEAD TIME WILL START UPON RECEIPT OF SIGNED APPROVAL DRAWING		

FOR INTERNAL USE ONLY PROJECT SIGN OFF	
SALES	
ENG.	
FAB.	
POWER	

DISTRIBUTOR'S NAME:		P.O.#
VESTIL MANUFACTURING		X
DRAWN BY: T.MOORE		W.O.#
DATE: 06/08/2009		X
REFERENCE: X	SCALE: 1:5	SALES: X
QUOTED LEAD TIME: X	QUOTE #	FILE NAME:
	X	30-007-128